

FITTING INSTRUCTIONS

REAR SPOILER KIT - DFT 10017

It is recommended that installation of this kit is carried out by a Rover Dealer.

Check that the kit contains the Parts listed below and read the instructions carefully before installation.

KIT CONTENTS

<u>DESCRIPTION</u>	<u>QTY</u>
REAR SPOILER	1
BLANKING PLUG	4
NUTSERT	4
SCREW	4
GROMMET	2
WAX SACHET	1

1. Examine the spoiler, note the four top fixing holes and the lower fixings that consist of two threaded studs and plastic clips.
2. Note where the two holes for the lower studs will have to be drilled and protect the tailgate paint work with a covering of self adhesive tape on these two areas.
3. Note where the four holes for the top fixings will have to be drilled and cover this area of the tailgate with masking tape.
4. Position the spoiler centrally on the tailgate and align the top edge of the spoiler just below the top radius of the tailgate panel (See Illustration A). Tape the top of the spoiler firmly into position on the tailgate.
5. Mark the position of the four top fixings onto the masking tape, remove the spoiler and centre punch the marks.

6. To avoid damage during the drilling operations the wiring harness and washer pipe must be removed from the tailgate. Disconnect the battery, remove the tailgate trim pad, disconnect the wiring to the rear wiper motor, disconnect the washer pipe, disconnect the heated rear window wires. To ease re-fitment fix flyleads to the ends of the wires and washer pipe and remove the harness and washer pipe from the tailgate.
7. Drill the four top fixing holes 7.1mm diameter in the tailgate outer panel. Treat the four holes with anti corrosion wax and fit the four insert nuts provided. Temporarily refit the spoiler with the screws provided.
8. Note the positions of the lower fixings and add double sided tape to the tailgate under these fixings.
9. Re-check that the bottom of the spoiler is aligned centrally on the tailgate and then gently press the spoiler lower fixings into the tape. Remove the spoiler and centre punch the middle of the marks in the tape.
- 10A. Examine the inside of the tailgate (See Illustration B), on vehicles having grommets filling the two holes adjacent to the lower corners of the tailgate glass, drill all the lower fixing holes 8.1mm diameter in the tailgate outer panel.
- 10B. On vehicles with no holes it will be necessary to provide access through the tailgate inner panel to allow fitment of the retaining nuts for the two studs in the spoiler. Note the marks made by the two studs and drill a hole 2mm diameter at each point through both the outer and inner tailgate panels. Open out the holes in the outer panel to 8.1mm diameter and drill the remaining fixing points 8.1mm diameter in the outer panel. Open out the two holes in the inner panel to 22mm diameter to allow fitment of the nuts and blanking grommets.
11. Treat all the holes with anti corrosion wax.
12. Before finally fitting the spoiler remove the remains of the tapes stuck to the tailgate and spirit wipe the area of the tailgate that the spoiler will cover when fitted.
13. Examine the gasket around the spoiler outer edge, if it is made of double sided tape remove the protective film.
14. Remember that when fitting the spoiler, once the double sided tape has come into contact with the tailgate, it will be very difficult to alter its position. Therefore, with the help of an assistant, offer up the spoiler into position and locate it with the top four fixing screws. Carefully line up the lower fixings and locate the plastic clips and studs. Fit the retaining nuts taking care not to drop them into the tailgate as recovery will be difficult. Fully tighten the screws and nuts. Apply gentle pressure around the spoiler to locate those areas with double sided tape. Finally fit the four blanking plugs to the spoiler.

15. Refit and reconnect the harness and washer pipe, reconnect the battery and check operation of the rear wash wipe and heated rear window. Remove all drilling swarf and refit the trim pad and grommets.
16. On vehicles without rear wash wipe, it is recommended that you fit tailgate struts Part No. BHE 39006.
17. Remove all finger marks and drilling swarf.

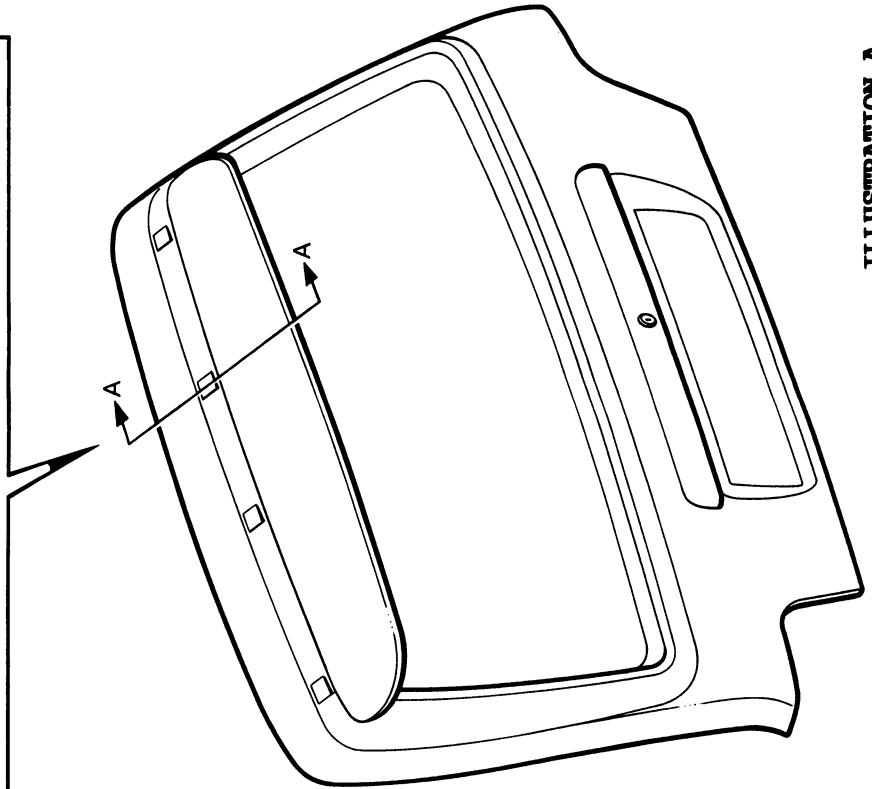
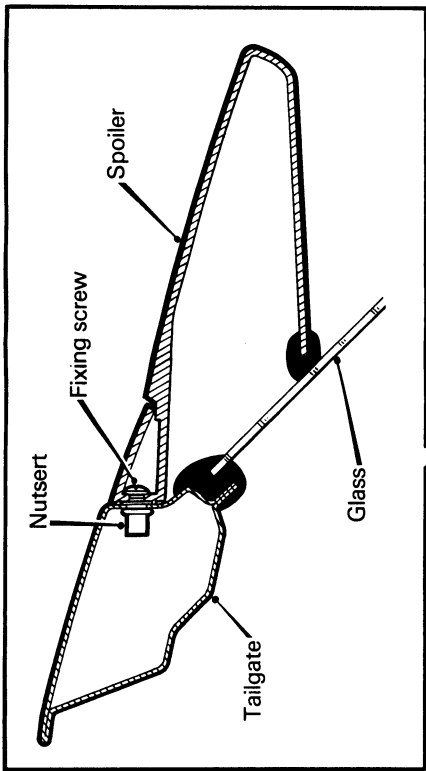

ILLUSTRATION A.

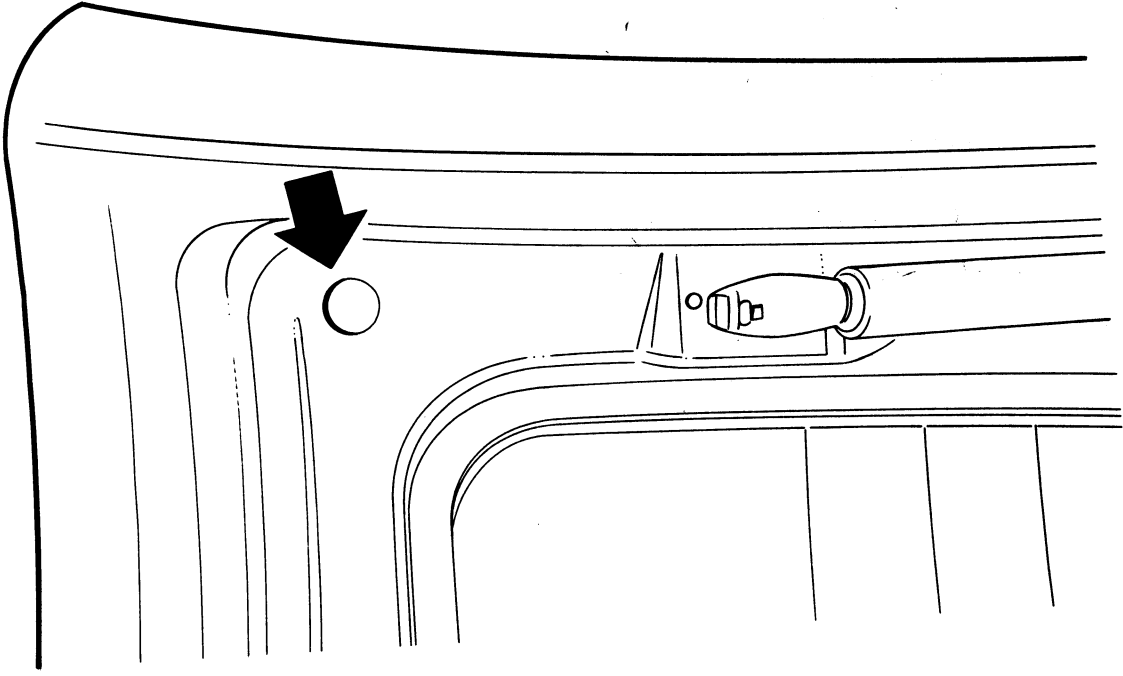

ILLUSTRATION B.